



**ANGLO BELGIAN
CORPORATION**

We power your future



ABC Evolve multi fuel motoren

23/03/2023

Koninklijke Gallois Genootschap

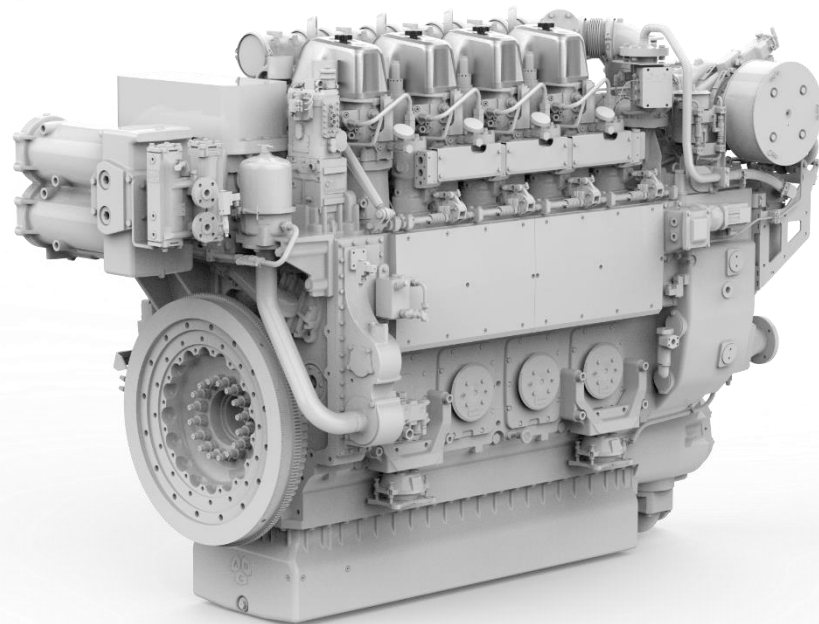



**ANGLO BELGIAN
CORPORATION**

We power your future

Company presentation Programme

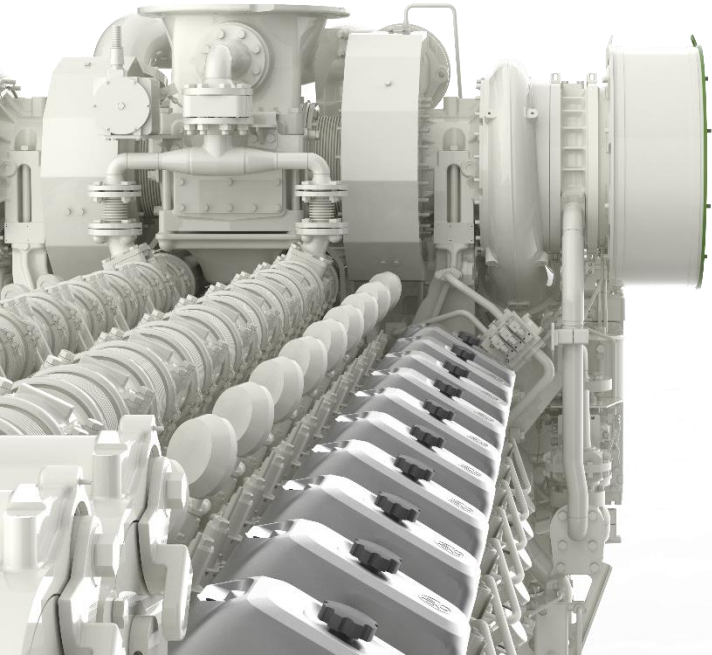

- ✓ ABC today
- ✓ The Ogepar Group
- ✓ Towards Decarbonisation
- ✓ Product Line-Up
- ✓ New developments
- ✓ EVOLVE

Company presentation

ABC today...

ABC is the oldest and largest privately owned
engine manufacturer in Europe



Marine propulsion



Power generation



Traction

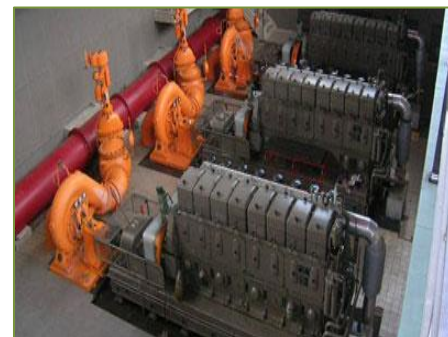

Industrial application



Company presentation

The OGEPAR Group



Ogepar Group

 1900 people

 T/O: 390 Mio €



Manufacturing of engines and turbos



Foundries



Contracting, energy & trading



Manufacturing & aftersales machine tools



Hotels & real estate



Automotive distribution



Company presentation

Vertical integration



Ogepar Group

85 % components within Ogepar Group

- ✓ Cost control
- ✓ Quality control
- ✓ Delivery control
- ✓ Parts control

HIGH GRADE OF VERTICAL INTEGRATION => added value



Company presentation

ABC today...



HQ & production facility in Gent (B)



360 people



2022 T/O: € 165 Mio.



> 80 % T/O = export

Company presentation

Continuous investments

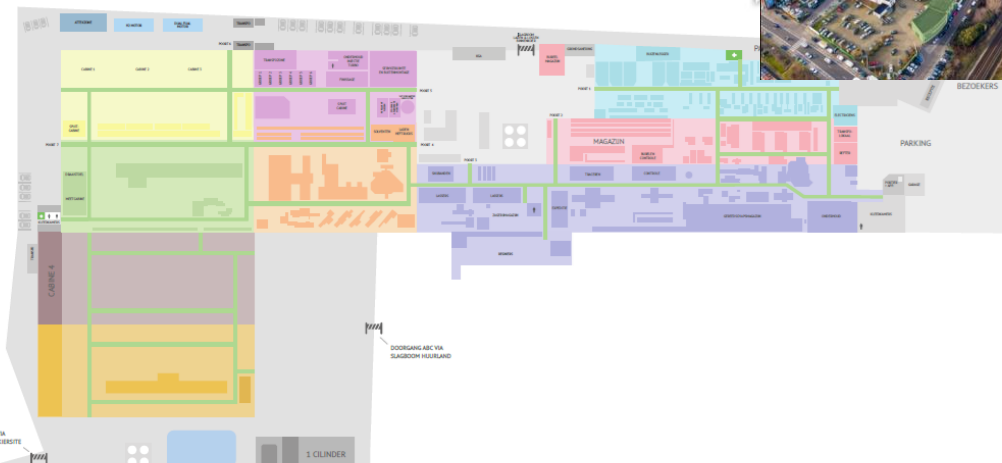

VYNCKIER SITE

- ✓ Surface: 10 ha
- ✓ 5 ha property of ABC since end of 2020
- ✓ Purchased for expansion ABC
- ✓ Several buildings including the iconic Manchester building
 - ✓ Protected monument
 - ✓ 5 floors (5.000 m²/floor)

Expansion

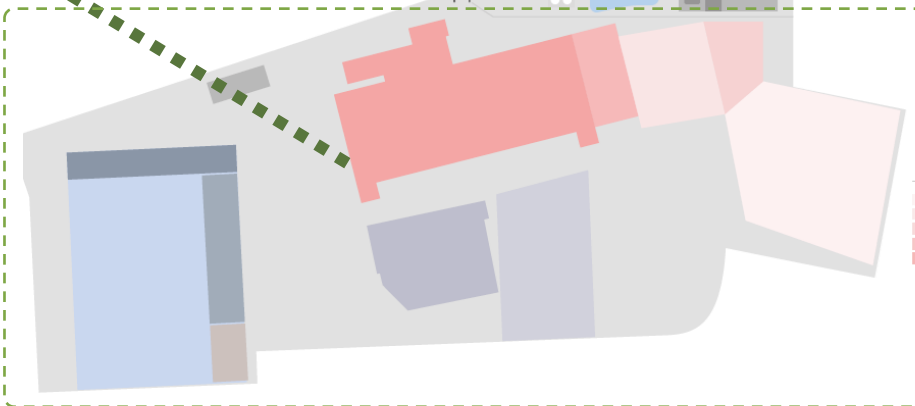



**ANGLO BELGIAN
CORPORATION**

We power your future

Company presentation **Production facility**

State-of-the-art machinery



Waldrich milling machine for
machining engine blocks up to 40 tons



**ANGLO BELGIAN
CORPORATION**

We power your future

Company presentation

Production facility

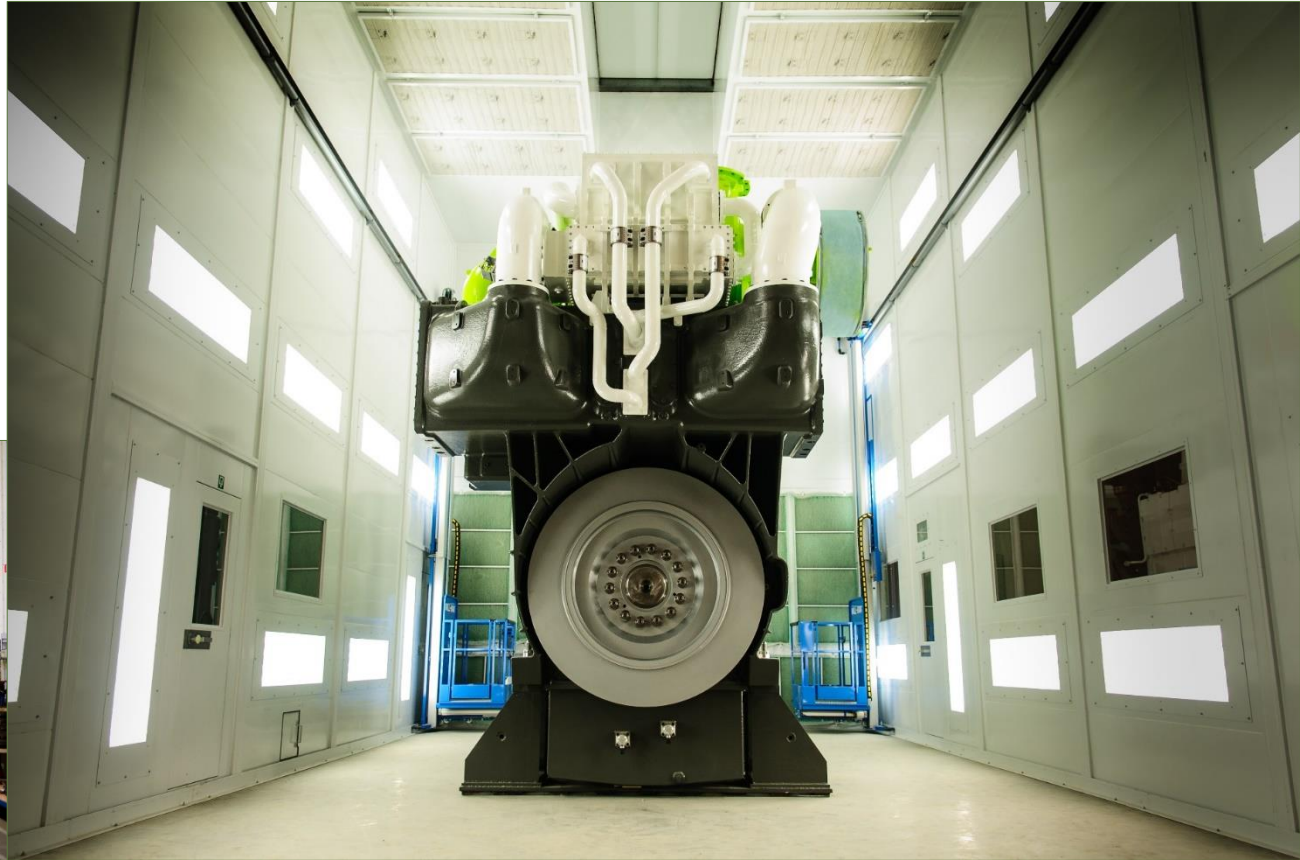

Company presentation

Production facility

Assembly – customized solutions



Extensive Quality Control

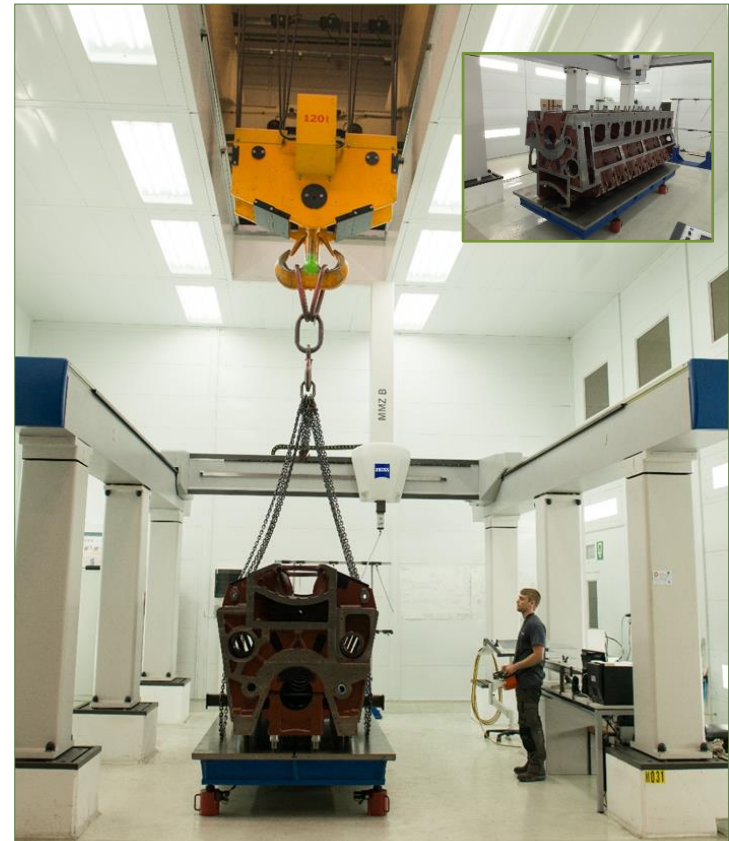



**ANGLO BELGIAN
CORPORATION**

We power your future

Company presentation R&D | in-house testing

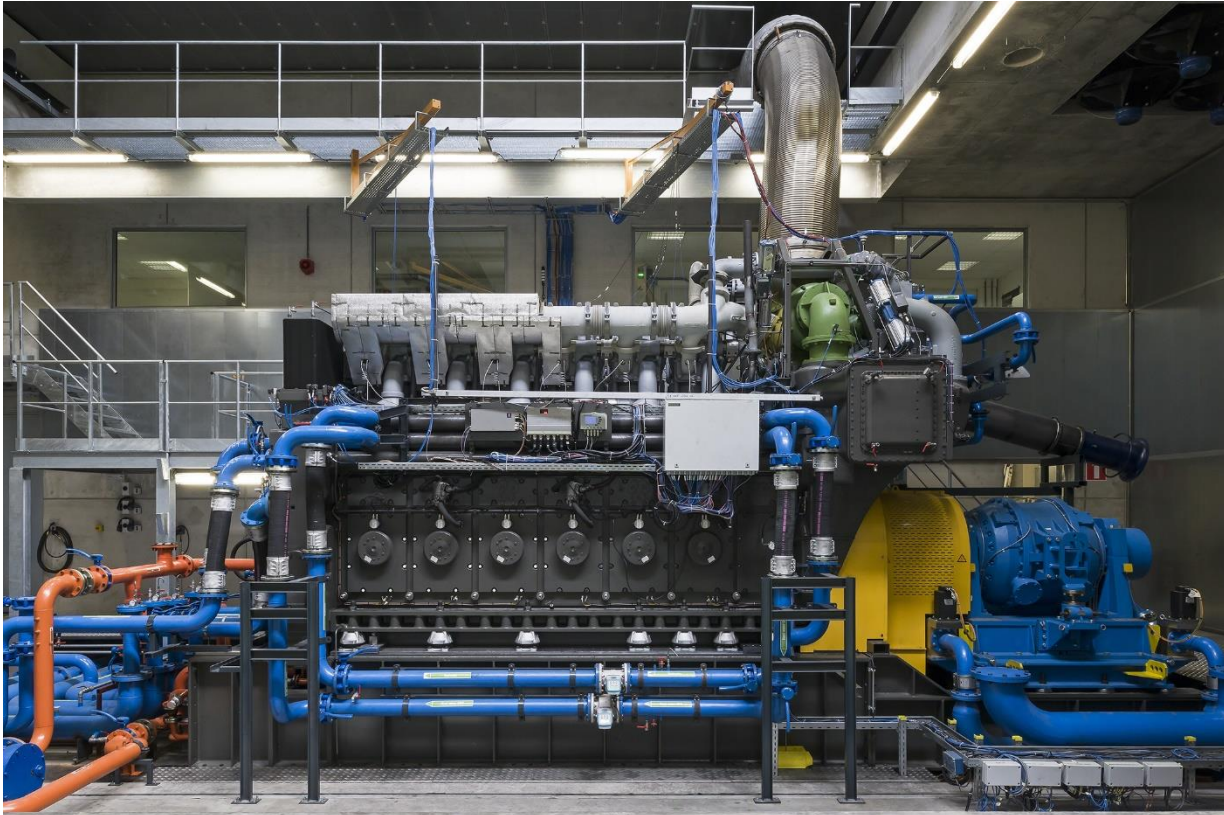



ANGLO BELGIAN CORPORATION

We power your future

World class customers

Marine, Traction & Nuclear



Hybrid
CNG



IMO-3





**ANGLO BELGIAN
CORPORATION**

We power your future

ABC References Power & Industry



Towards Decarbonisation

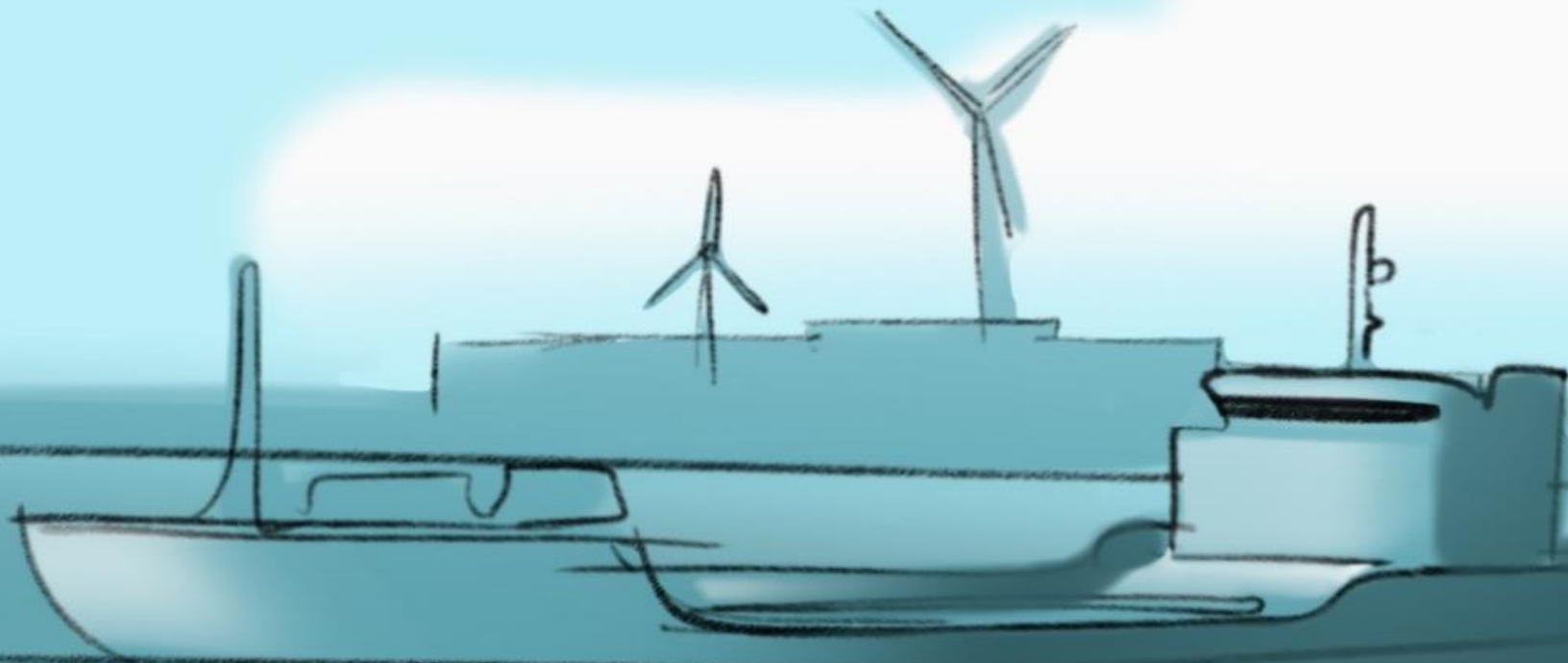



Why is it an issue ? Emissions in Maritime Transport

Maritime transport – a substantial CO₂ emitter

>138 million tonnes of CO₂ in 2018

- Over 3% of total EU CO₂ emissions
- Comparable to the CO₂ emissions of Belgium
- According to projections, CO₂ emissions from maritime transport are likely to grow in the future, reinforcing the need for CO₂ reduction efforts.

>44 million tonnes of fuels consumed

- 70% heavy fuel oils, which is a residual fuel and a heavy pollutant
- 20% marine gas oil and diesel
- 3% Liquefied Natural Gas (LNG)
- Represents around 90% of total marine fuel sales in EU ports.

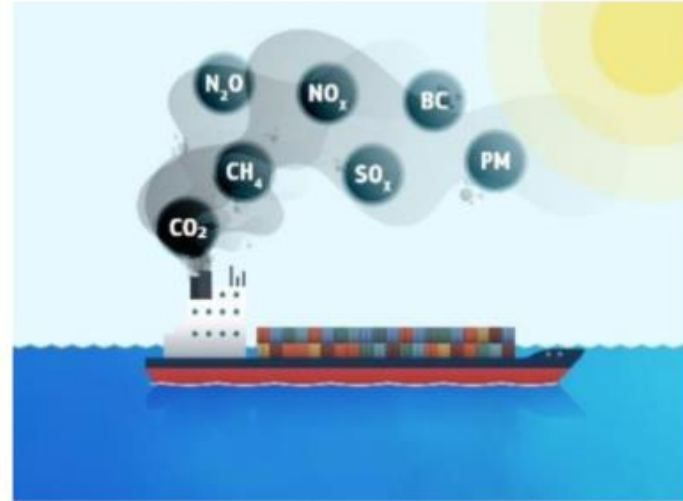

90% of goods via Sea

IMO 1-2-3

Low Sulfer diesel

**EEIX / Operating profile (speed, routes, design hull..
CO₂ tax**

A chaos of technologies Who's the champion.. In what?

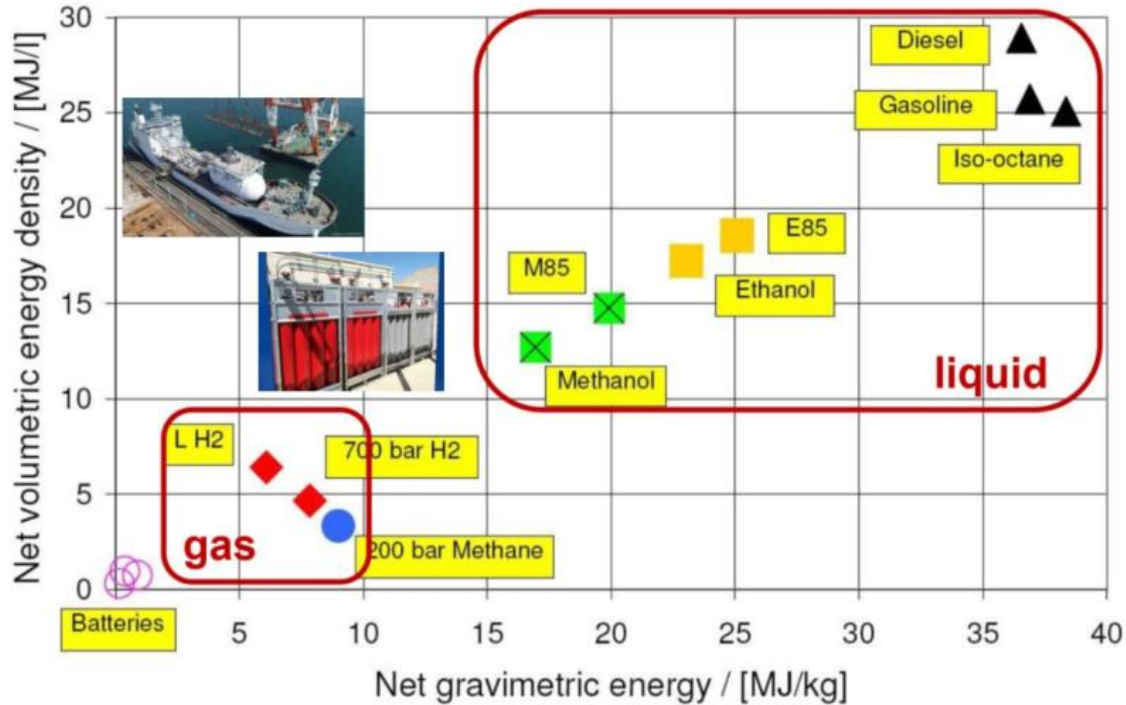

A chaos of technologies Who's the champion.. In what?



	HYDROGEN	MGO
Boiling Temperature (° C)*	-253	180-360
Lower Flammability Limit (% vol. fraction)***	4.0	0.7
Upper Flammability Limit (% vol. fraction)***	75.0	5
Maximum Burning Velocity (m/s)	3.15	-
Minimum Ignition Energy (mJ)***	0.017	-

A chaos of technologies Who's the champion.. In what?



- Cost of *green* H₂:
 - Today: >6 €/kg
 - Future projections:
 - 4 €/kg
 - Imported green H₂: 2-3 €/kg

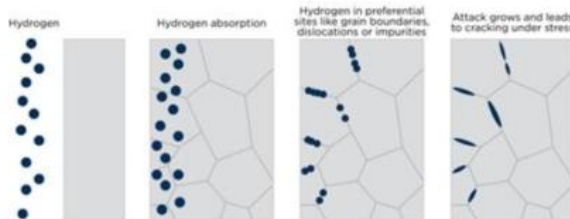

- Training
- Bunkering time
- Control of systems
- New regulation
- Access in ports? Cities



ANGLO BELGIAN CORPORATION

We power your future

A chaos of technologies
Who's the champion.. In what?

How Much Space Do You Need?

100m Superyacht requires 300m³ of fuel (including 20% reserve) to cross from Gibraltar to Florida.

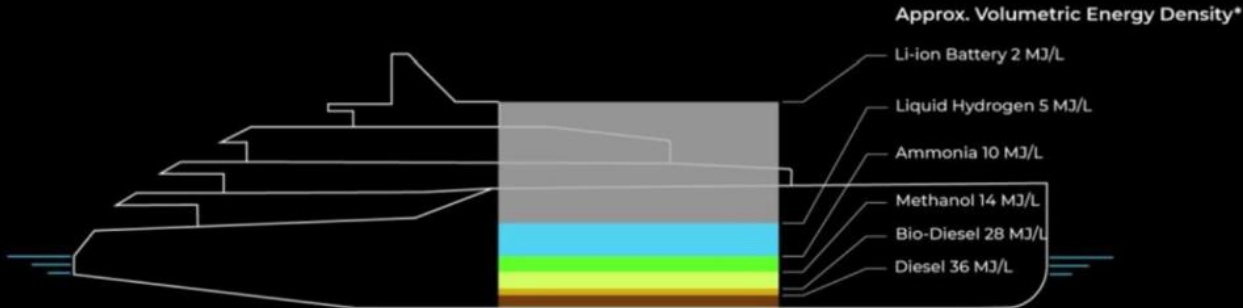

With tank width and length remaining the same, the diagram shows the additional height required for the various alternative energy carriers.

*Based on DNV GL. Comparison of Alternative Marine Fuels





**ANGLO BELGIAN
CORPORATION**

We power your future

Company presentation **Future fuels**





Company presentation Complex dilemmas

The Color Palette of the Colorless Hydrogen

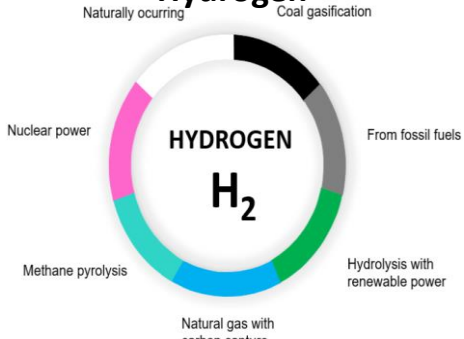

Technical potential for producing green hydrogen under USD 1,5/kg by 2050, in EJ



Published: 23 Jan 2023, 09:44 UTC • By: [Cristian Agatie](#)

Li-Ion batteries in electric vehicles pose a significant fire risk, which was further emphasized after the Felicity Ace cargo ship sank almost a year ago. Following a safety assessment regarding fire risks, a Norwegian ferry company decided to ban all but purely ICE vehicles from its vessels.



HOME / NEWS / PARKING GARAGE BANS ALL EVS AND HYBRIDS
Parking Garage Bans All EVs And Hybrids





**ANGLO BELGIAN
CORPORATION**

We power your future



“Prediction is very difficult,
especially if it is about the future”
– Niels Bohr

What ABC believes in.. Multiple approach Fuel Flexibility

Methanol future

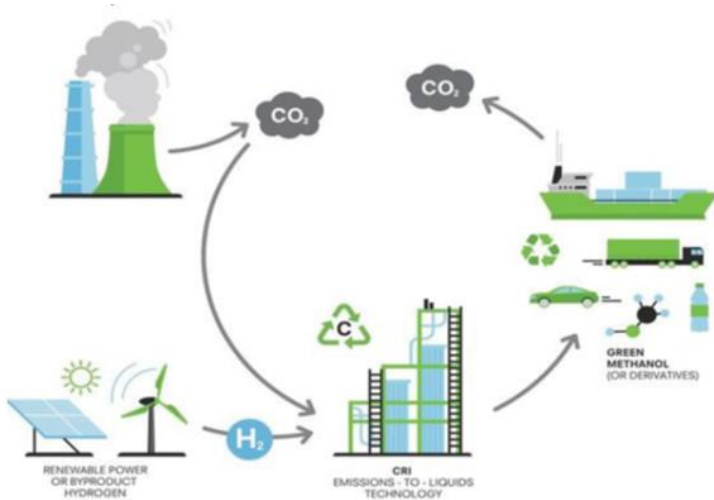

Hydrogen future

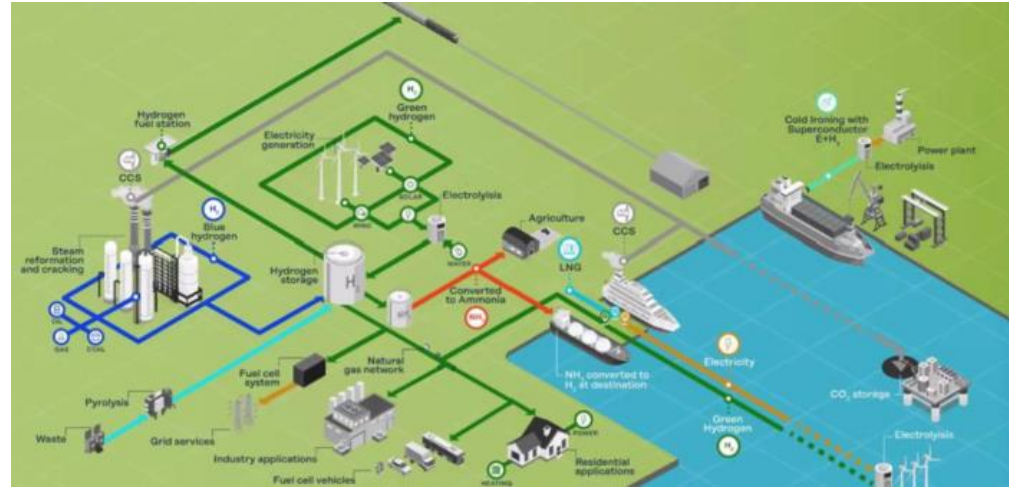

Based on carbon capture & renewable H₂

Product Line-Up

From 0.8 to 10.5 MW

Power range

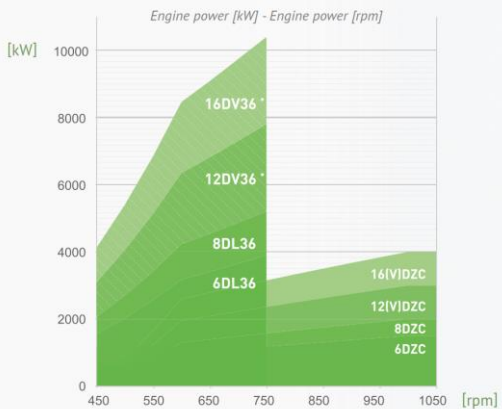

DZC series



Bore: 256 mm
Stroke: 310 mm

6 & 8 cylinders in line

Up to 1,000 rpm
Up to 2,000 kW



6/8DZ

(V)DZC series

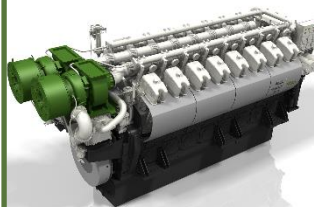

Bore: 256 mm
Stroke: 310 mm

12 & 16 cylinders in V

Up to 1,000 rpm
Up to 4,000 kW



12/16DZ

DL36 series

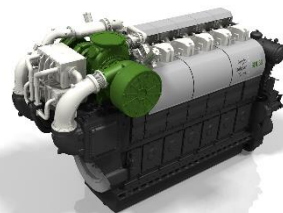

Bore: 365 mm
Stroke: 420 mm

6 & 8 cylinders in line

Up to 750 rpm
Up to 5,200 kW



6/8DL36

DV36 series



Bore: 365 mm
Stroke: 420 mm

12 & 16 cylinders in V

Up to 750 rpm
Up to 10,500 kW



12/16DV36

Company presentation

Developing Flexibility

Exhaust aftertreatment

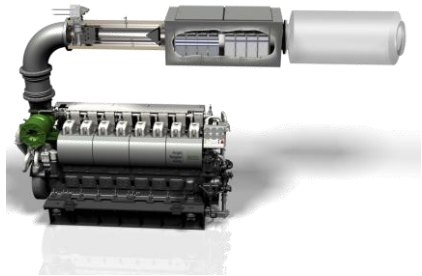

Methanol

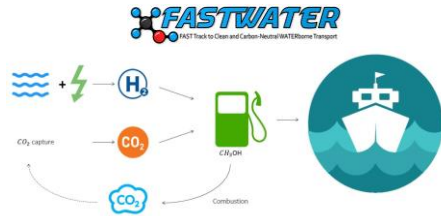

Hydrogen

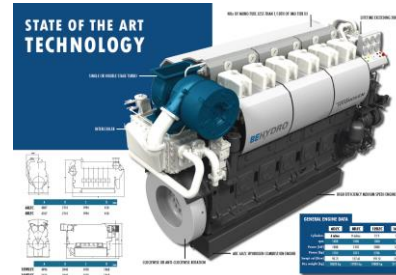

Digital Twins



Company presentation

Don't forget Diesel

Full range available in diesel with :

- IMO2 mechanical
- IMO 3 SCR
- StageV, EPA4 SCR+DPF
- Hybrid solutions available

Flexible Power Solutions for Variable Operational Profiles

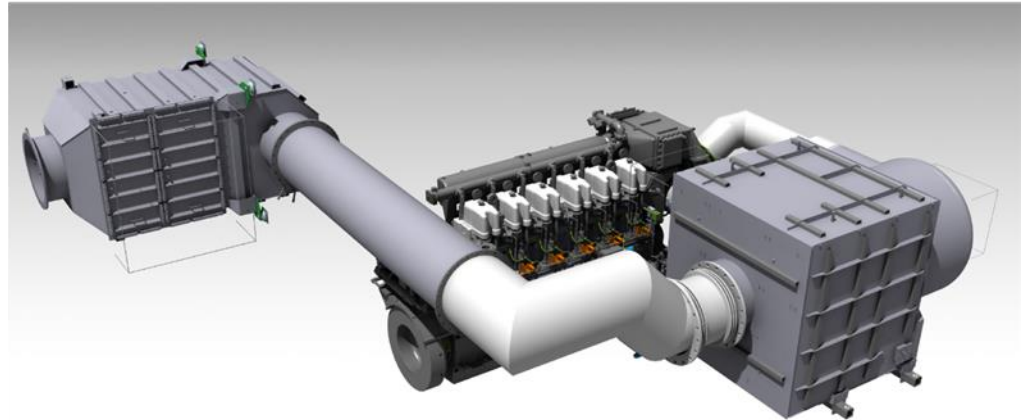
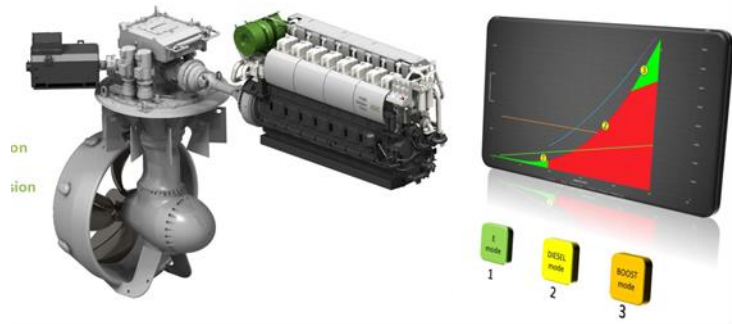



Company presentation

Hydrogen (H₂)



BEHYDRO

2

THE HYDROGEN FUTURE IS NOW



ANGLO BELGIAN CORPORATION

We power your future

Company presentation Hydrogen (H₂)

Sept 17, 2020

Official Launch BeHydro and the Dual Fuel Hydrogen Engine (DZD H₂)

BEHYDRO₂
THE HYDROGEN FUTURE IS NOW

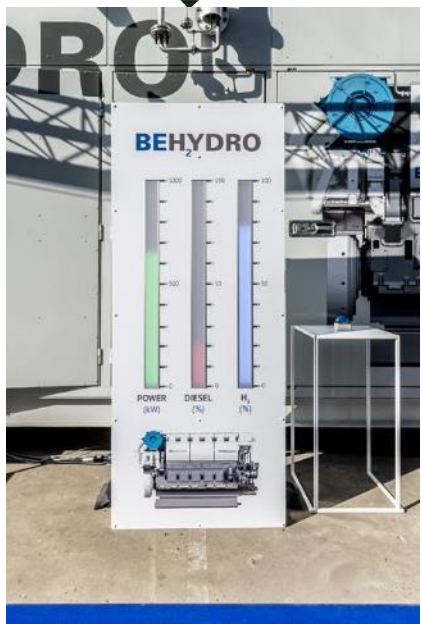

Dual Fuel



Company presentation

Hydrogen (H₂)

BEHYDRO₂
THE HYDROGEN FUTURE IS NOW



DUAL FUEL

DZD H₂



Bore: 256 mm
Stroke: 310 mm

6 & 8 cylinders in line

Up to 1,000 rpm
Up to 1,330 kW
Up to 1,810 HP



6/BDZ

DZD H₂



Bore: 256 mm
Stroke: 310 mm

12 & 16 cylinders in V

Up to 1,000 rpm
Up to 2,670 kW
Up to 3,630 HP



12/16DZ



BE POWERFUL

- ✓ Power range: 500 kW – 2,670 kW
- ✓ Quick reaction to variable load
- ✓ Possible to operate on less purified H₂



BE SUSTAINABLE

- ✓ 85% CO₂ reduction
- ✓ EU Stage V compliant in combination with DPF/SCR
- ✓ No use of rare materials (lithium, zinc, cobalt, platinum, rare earths, ...)



BE COMPETITIVE

- ✓ Long lifetime (+200,000 engine running hours)
- ✓ Easy maintenance
- ✓ Availability of spare parts / supply chain (no use of rare or conflict materials)



BE FLEXIBLE

- ✓ Operates on 85% H₂ AND 15% liquid fuel
- ✓ Possible to operate on 100% liquid fuel

Company presentation

Hydrogen (H₂)



Technical details

- Country: Belgium
- Ship's name: Hydrotug 1
- Type: Tugboat
- Shipyard: Astilleros Armon
- Commissioning: 2023
- Engine: **2x 12DZD H₂**



Company presentation Hydrogen (H₂)

BEHYDRO
2
THE HYDROGEN FUTURE IS NOW

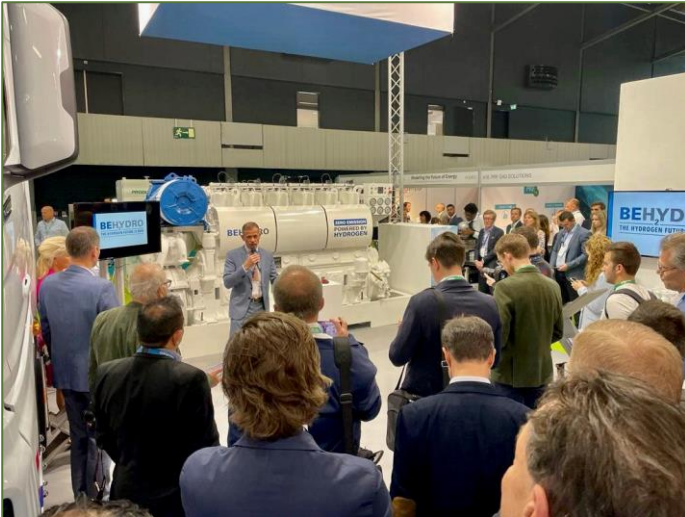

Launch of the 100% H₂ engine range at the World Hydrogen Summit in Rotterdam
(May 2022)

Company presentation

Hydrogen (H₂)

BEHYDRO
2
THE HYDROGEN FUTURE IS NOW



100% H₂ GAS

DZ H₂



Bore: 256 mm
Stroke: 310 mm

6 & 8 cylinders in line

Up to 1,000 rpm
Up to 1,330 kW
Up to 1,810 HP



DZ H₂



Bore: 256 mm
Stroke: 310 mm

12 & 16 cylinders in V

Up to 1,000 rpm
Up to 2,670 kW
Up to 3,630 HP



BE POWERFUL

- ✓ Power range: 500 kW – 2,670 kW
- ✓ Possible to operate on less purified H₂



BE SUSTAINABLE

- ✓ 100% CO₂ reduction
- ✓ Very low NO_x and soot
- ✓ EU Stage V compliant WITHOUT DPF/SCR
- ✓ No use of rare materials (lithium, zinc, cobalt, platinum, rare earths, ...)



BE COMPETITIVE

- ✓ Long lifetime (+200,000 engine running hours)
- ✓ Easy maintenance
- ✓ Availability of spare parts / supply chain (no use of rare or conflict materials)



100% H₂ GAS



**100% HYDROGEN ENGINE
FOR HEAVY-DUTY APPLICATIONS**



**ANGLO BELGIAN
CORPORATION**

We power your future

Company presentation

Methanol (CH₃OH)

 **POWERED BY
METHANOL**

Company presentation

Methanol (CH₃OH)

POWERED BY METHANOL



DUAL FUEL

DZD MeOH



Bore: 256 mm
Stroke: 310 mm

6 & 8 cylinders in line

Up to 1,000 rpm
Up to 1,768 kW
Up to 2,400 HP



DZD MeOH



Bore: 256 mm
Stroke: 310 mm

12 & 16 cylinders in V

Up to 1,000 rpm
Up to 3,536 kW
Up to 4,800 HP



Power range: 955 kW 3,536 kW



High energy density



CO₂ neutral fuel when produced with renewable energy



Liquid fuel offering storage flexibility in vessel design



Safe double-walled MeOH system



Compact fuel preparation compartment



Low pressure fuel injection (< 10 bar)



IGF code compliant



Retrofit of existing ABC engines



Long lifetime: +200,000 engine running hours

Company presentation

Methanol DZD – Retrofit concept

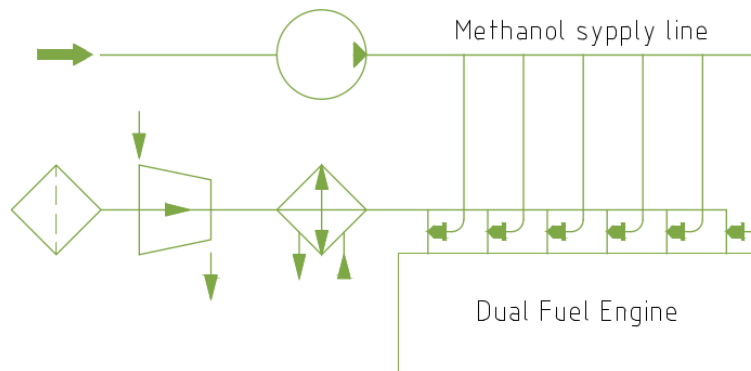

Port injection concept

- Scalable to DZ engines in the field
- Cost effective
 - Limited design changes
 - Low pressure injection (IGF code <10bar)
- Allow more homogenous air-fuel mixture

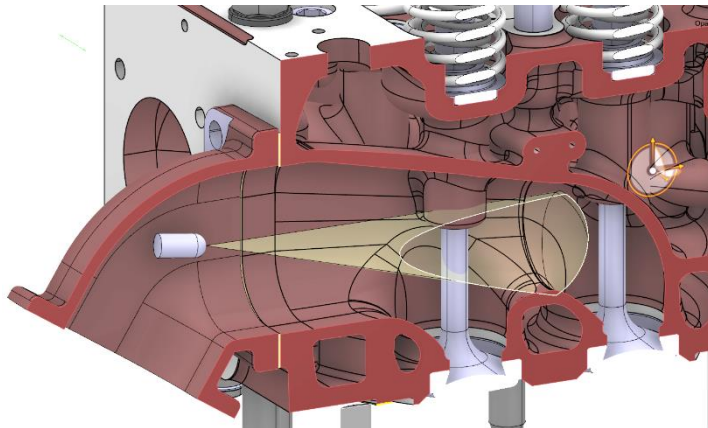

Company presentation

Methanol (CH_3OH)

“Developing and Demonstrating an Evolutionary Pathway for Methanol Technology and Take-up”



DUAL FUEL



Project: First conversion to DZD MeOH

Methanol Retrofitting
Tugboat Port of Antwerp-Bruges

Methanol Dual Fuel Engine
Launch end of April 2023



Methanol poisoning via:

- Air
 - Skin and eye contact
 - Oral
- Double walled piping and tank system needed
→ Safety limit is mainly personal safety, not explosion limit

	Max value continuous	Max value short term	Smell	Lethal value	Lower explosion limit
	8h/day 40h/week	15 min			
	ppm	ppm	ppm	ppm	ppm
Methanol	200	250	2 000	6 000	60 000
Gasoline (reference)	300	500	0.025	10 000	

Exhaust layout

Critical zone



- Critical zone: from exit turbocharger to exit from reactor: contains high CO values as normal with DF engines
- Leakage in this zone is to be avoided
- Ventilation to be foreseen
- CO detection advised
- **Safety onboard to be ensured for crew.**

With SCR, an oxicat is integrated

→ CO and HC are oxidized → reduces CO

and HC like diesel values but creates heat.

- High CO and HC values reduced with DOC.
- Temperature increase over DOC due to exothermic reaction.
- Exhaust line needs to withstand high temperatures, incl boiler



- Components downstream of the reactor to be checked for high temperature ~600°C
- Gaskets and insulation to be checked
- Thermal expansion of exhaust line to be checked.

Fuel for oxidation catalyst

- Low sulfur fuel (< 50ppm) in order not to poison the DOC.
- Testing with higher S fuels but not validated yet.
- Poisoning with S can most likely be regenerated, question is if this is possible without disassembly
- Oxi cat is not obligated to reach IMO tier III emission levels, but is standard provided by ABC to reduce harmful substances in exhaust (CO and Formaldehyde)

Company presentation

New engine family: EVOLVE

EVOLVE
OUR ENGINES ARE FLEXIBLE. YOUR FUTURE IS SAFE



Future Proof

Fuel Flexible

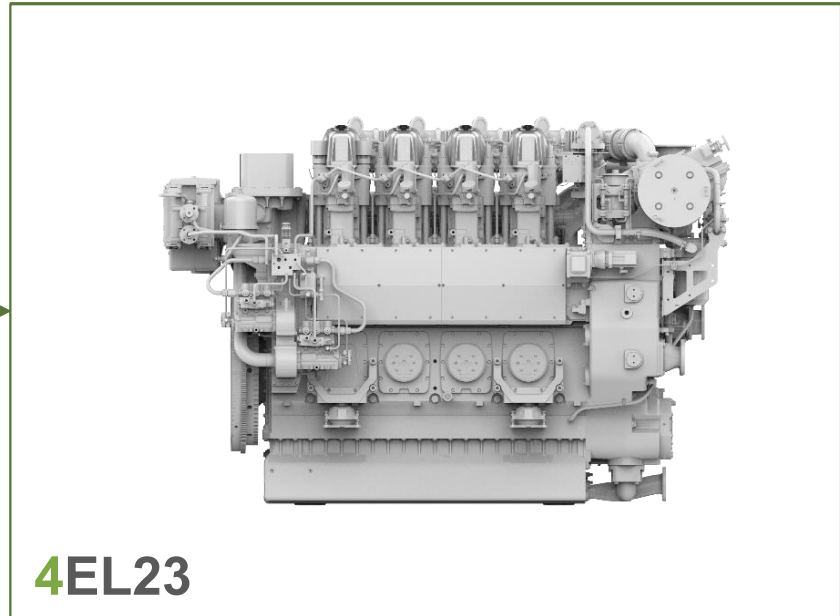

4EL23

Company presentation

New engine family: EVOLVE

EVOLVE

OUR ENGINES ARE FLEXIBLE. YOUR FUTURE IS SAFE

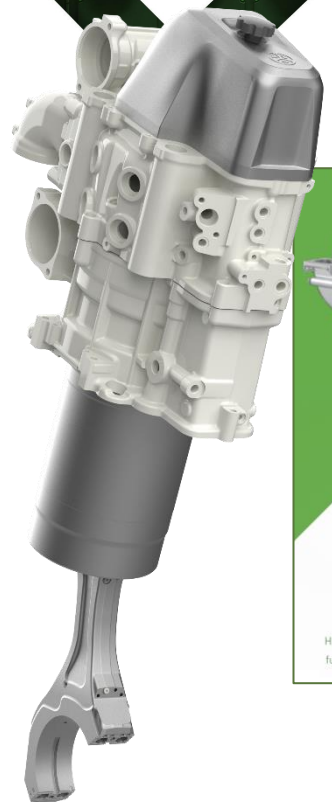



Liquid fuel
Highly efficient Common Rail or PLN fuel injection system for liquid fuels.

Dual fuel
Micro pilot liquid fuel injection combined with gas injection system.





Spark ignited
100 % gas using a spark plug.

**Less is more:
how care for the environment creates
a win-win situation**

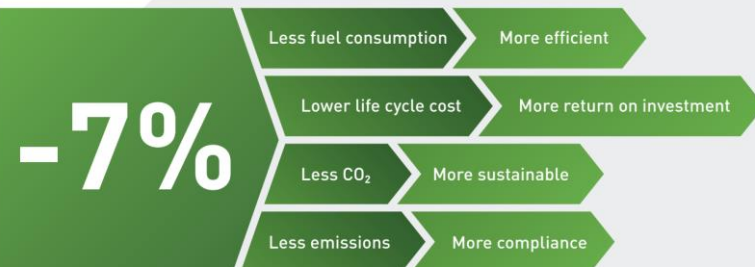

Common power unit for all possible fuels

Company presentation

New engine family: **EVOLVE**

EVOLVE

OUR ENGINES ARE FLEXIBLE. YOUR FUTURE IS SAFE

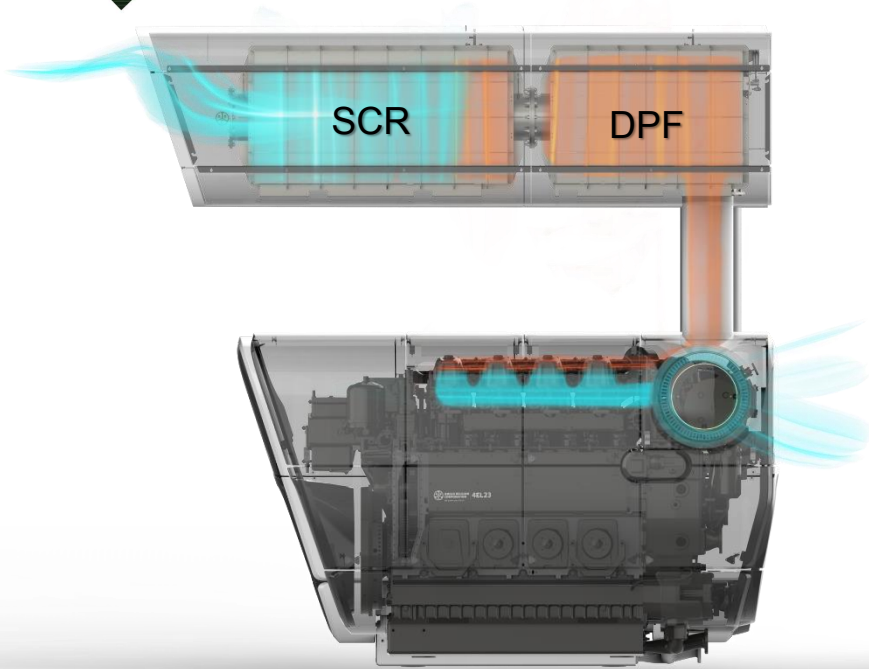

Compact Exhaust After-treatment System (EATS):

- ✓ Diesel Particulate Filter (DPF)
- ✓ Selective Catalytic Reduction (SCR) with integrated mixing pipe



Company presentation New engine family: **EVOLVE**



**World Premiere of the EVOLVE 4EL23
at Europort in Rotterdam (Nov. 2021)**

Company presentation

New engine family: **EVOLVE**

EVOLVE

OUR ENGINES ARE FLEXIBLE. YOUR FUTURE IS SAFE

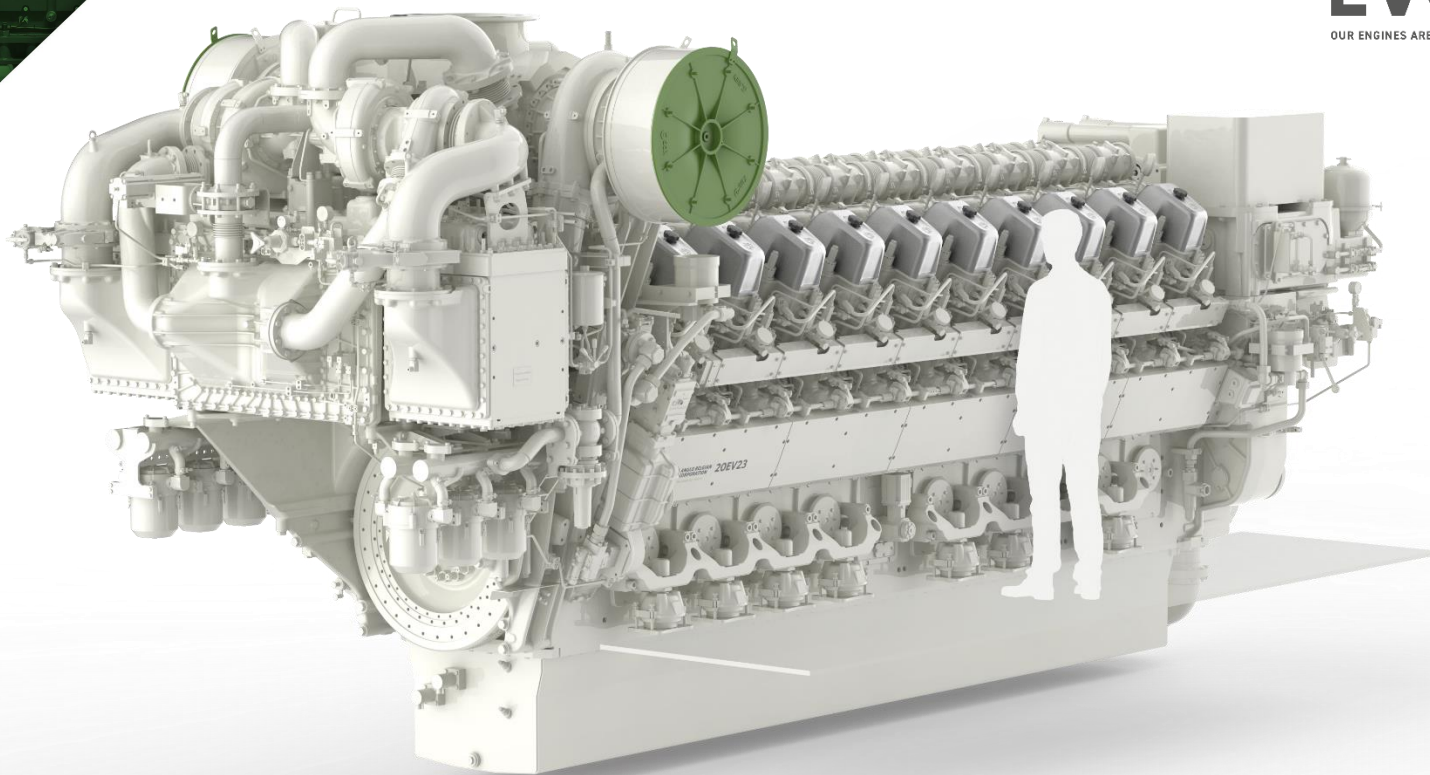

20EV23

Company presentation

New engine family: EVOLVE

EVOLVE

OUR ENGINES ARE FLEXIBLE. YOUR FUTURE IS SAFE

20EV23

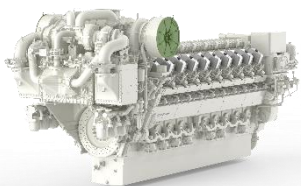

Bore: 230 mm
Stroke: 310 mm

20 cylinders in V

Up to 1,200 rpm
Up to 7,200 kW
Up to 9,790 HP

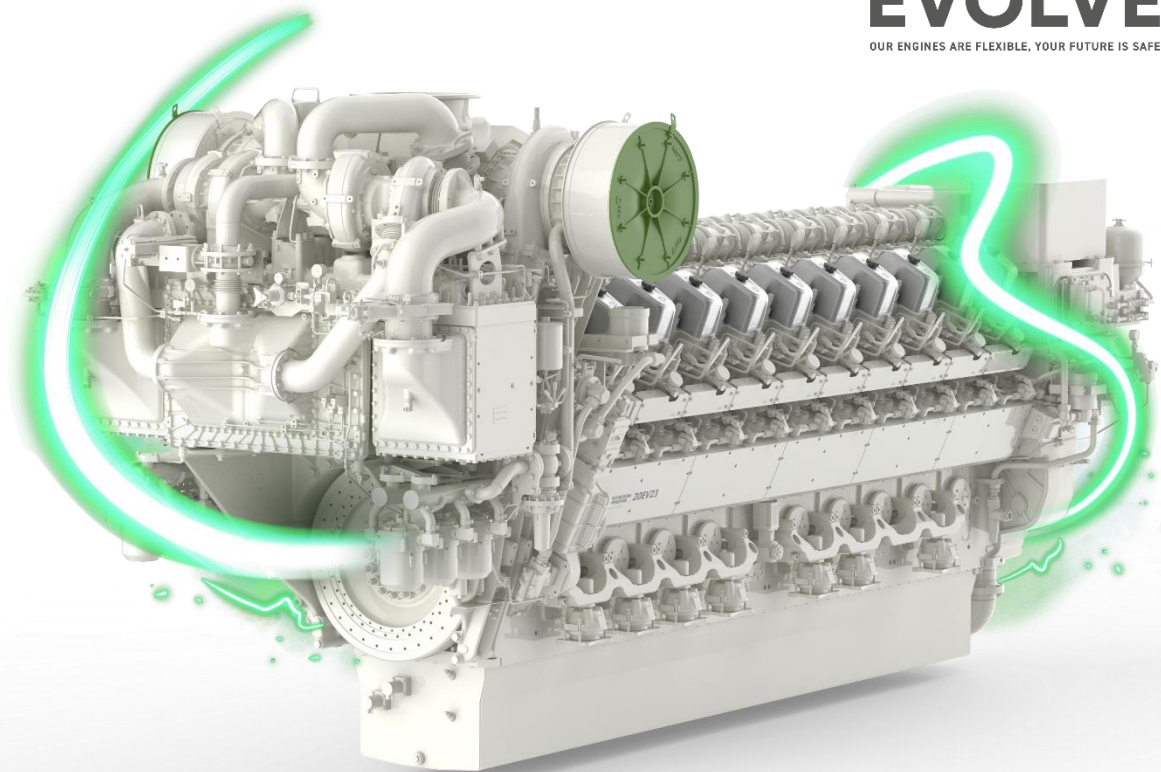

Company presentation New engine family: **EVOLVE**



**World Premiere of the EVOLVE 20EV23
at SMM in Hamburg (Sept. 2022)**

Company presentation R&D | in-house testing



SINGLE CYLINDER ENGINE

- ✓ In-house designed test bed
- ✓ Modular test environment
- ✓ Cost-saving and accelerated testing process of all possible fuels
- ✓ Extrapolation of acquired data to complete engines
- ✓ Simulation of extreme conditions
- ✓ Collaboration with University of Ghent



Testing to the limits for maximum reliability

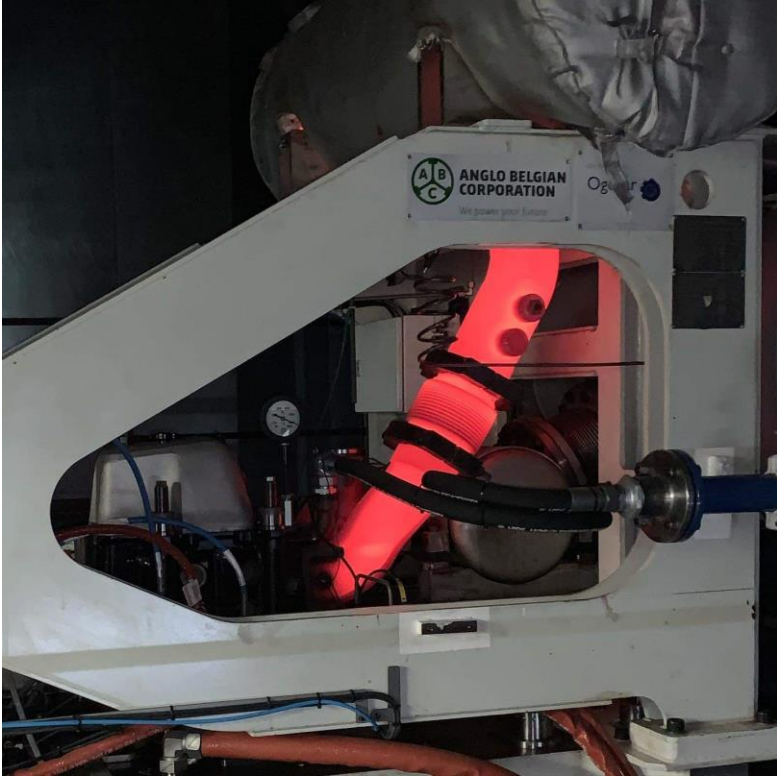

Phase 3: Testing on testbench 4EL23



There is not 1 future fuel

Small distance → Battery powered solutions

Fluctuating load → Hybrid, optionally 'plug in'

Cheapest fuel? → Hydrogen, DF or SI for land

Limited storage → Bio Diesels, Methanol, DF or SI for land

Near zero emissions → Aftertreatment needed



**ANGLO BELGIAN
CORPORATION**

We power your future



**ANGLO BELGIAN
CORPORATION**

We power your future



Company presentation Q&A



**Thank you for
your attention!**



www.abc-engines.com